



ONE TWIN PINES LANE,  
SUITE 110  
BELMONT, CA 94002  
(650) 595-7422  
www.belmont.gov

## Community Development Permit Center VENTED WALL FURNACE (M4)

LAST REVISED:  
**2022 CA MECHANICAL CODE**  
**907**

BUILDING OFFICIAL:  
**DINO FRANCESCONI**

### 907.0 Wall Furnaces.

**907.1 Installation.** Wall furnaces shall be installed in accordance with the following:

- (1) Listed wall furnaces shall be installed in accordance with their listings and the manufacturer's installation instructions. Wall furnaces installed in or attached to combustible material shall be listed for such installation.
- (2) Unlisted wall furnaces shall not be installed in or attached to combustible material. (NFPA 54:10.27.1.2)
- (3) Vented wall furnaces connected to a Type B-W gas vent system listed for a single story shall be installed in single-story buildings or the top story of multistory buildings. Vented wall furnaces connected to a Type B-W gas vent system listed for installation in multistory buildings shall be permitted to be installed in single-story or multistory buildings. Type B-W gas vents shall be attached directly to a solid header plate that serves as a firestop at the point and that shall be permitted to be an integral part of the vented wall furnace (see Fig. 907.1). The stud space in which the vented wall furnace is installed shall be ventilated at the first ceiling level by installation of the ceiling plate spacers furnished with the gas vent. Firestop spacers shall be installed at each subsequent ceiling or floor level penetrated by the vent. (NFPA 54.10.27.1.3)
- (4) Direct-vent wall furnaces shall be installed with the vent-air intake terminal in the outdoors. The thickness of the walls on which the furnace is mounted shall be within the range of wall thickness marked on the furnace and covered in the manufacturer's installation instructions. (NFPA 54:10.27.1.4)
- (5) Panels, grilles, and access doors that are required to be removed for normal servicing operations shall not be attached to the building. For additional info on the venting of wall furnaces, see Section 802.0 in this code. (NFPA 54:10.27.1.5)

Installation of B-W gas vent for each subsequent ceiling or floor level of multistory buildings

Fire stop spacers supplied by manufacturer of B-W gas vent

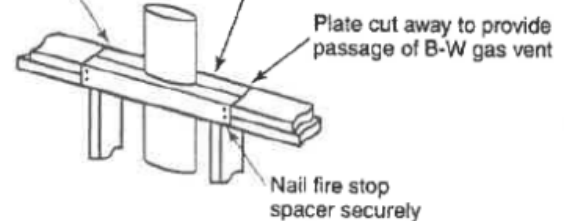

Installation of B-W gas vent for single-story buildings or for first-floor of multistory buildings

Ceiling plate spacers to center B-W gas vent in stud space — nail securely at both ends

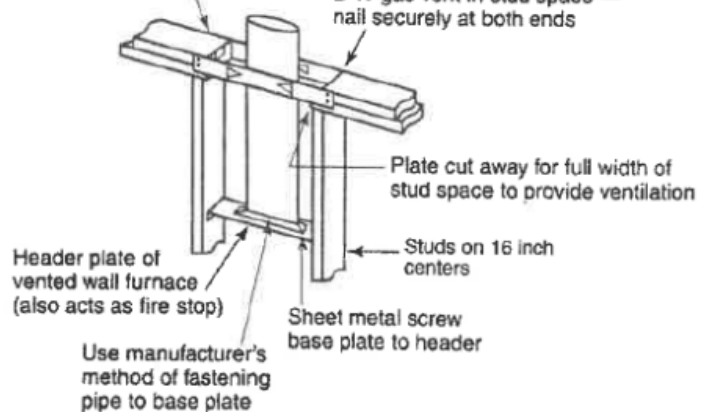

For SI units: 1 inch = 25.4 mm

**FIGURE 907.1**  
**INSTALLATION OF TYPE B-W GAS VENTS FOR**  
**VENTED WALL FURNACES**  
**[NFPA 54: FIGURE 10.27.1.3]**